



Medallion Fence

10651 KEELE STREET
 MAPLE, ONTARIO L6A 3Y9
 (T) 905-832-2922 || 1-800-794-1564 || (F) 905-832-1564
 info@medallionfence.com || www.medallionfence.com

Medallion Fence

STYLE:
CAVALIER-DR-SF

SERIES:
FAIRMONT™

SINGLE-GATES OPENINGS
 AS REQUIRED 36", 48"
 OR 60" STANDARD

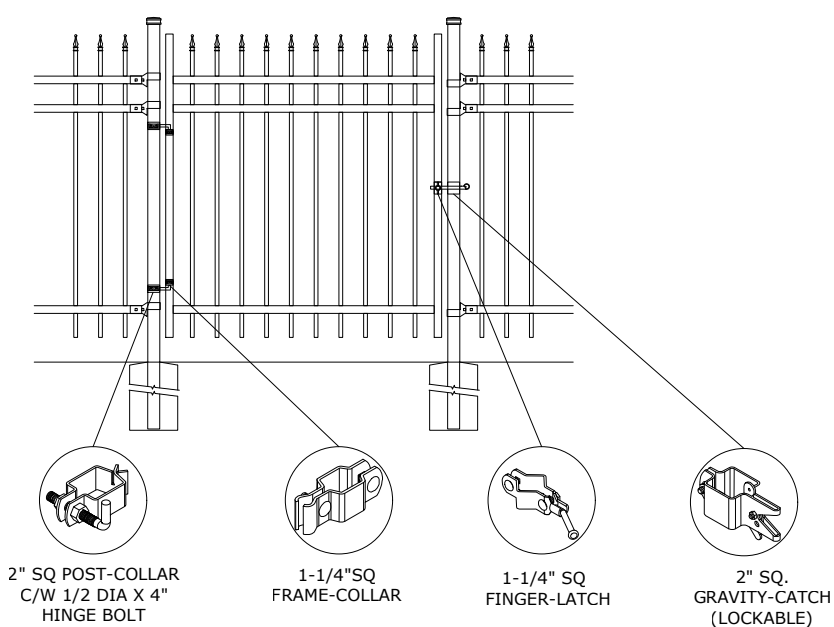

STANDARD POST SETTING - 94" [2388MM]
 STANDARD PANEL WIDTH - 92" [2337MM]
 3 1/2" [89MM] [BETWEEN PICKETS]

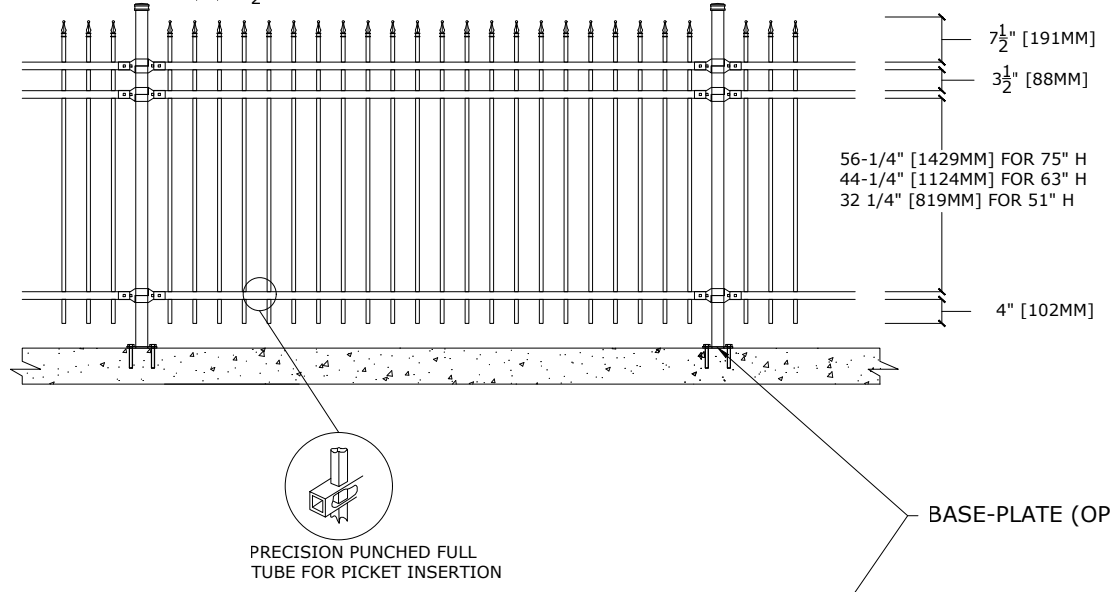

DOUBLE-GATES OPENINGS AS
 REQUIRED 72", 96" OR 120"
 STANDARD

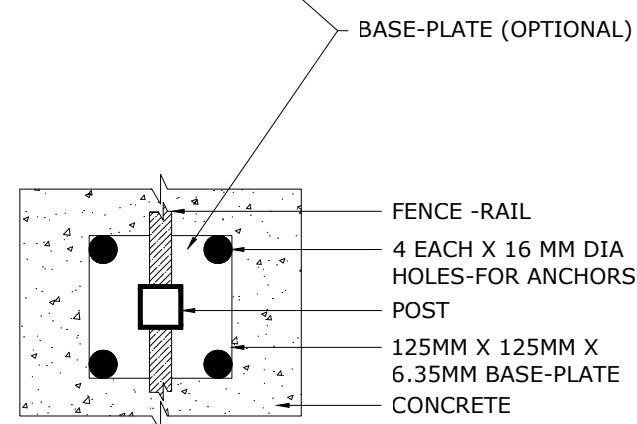
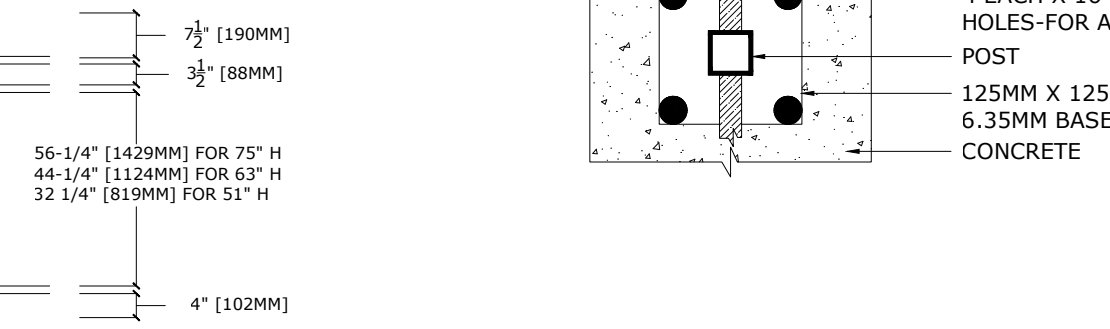
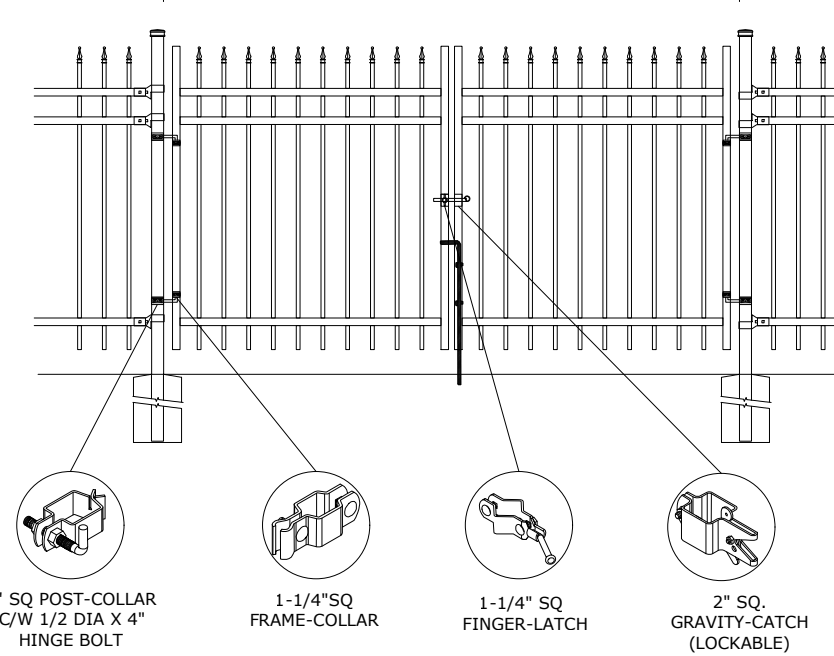

MATERIAL SPECIFICATIONS:
 ARMOUR-SHIELD™
 BY MEDALLION FENCE

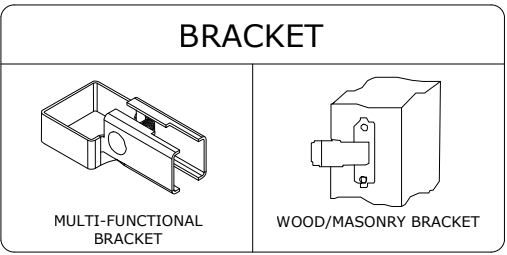
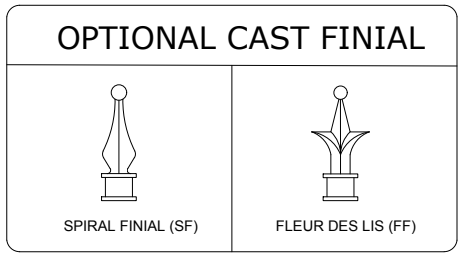
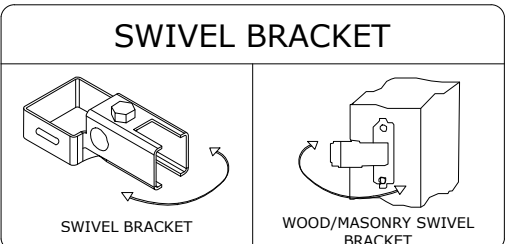
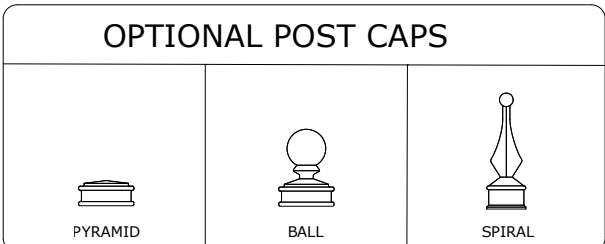

SPECIFICATIONS

TUBE COMPOSITION - POSTS , RAILS & PICKETS

- MINIMUM YIELD STRENGTH: 45 KSI (310 MPA)
- MINIMUM TENSILE STRENGTH: 55 KSI (380 MPA)
- ASTM A787 (TUBE)
- TUBE MANUFACTURED FROM PRE-COATED ALUMINUM-ZINC COATED STEEL WITH COATING DESIGNATION AZ50 CONFORMING TO ASTM A792/A792M

MATERIAL DIMENSIONS

PICKET	5/8" x 5/8" (16mm x 16mm) 18 GA
RAILS	1-1/4" x 1-1/4" (32mm x 32mm) 16 GA
POSTS REGULAR or BASE-PLATED	2" x 2" (51mm x 51mm) 16 GA or 14 GA
OPTIONAL POST REGULAR or BASE-PLATED	2-1/2" x 2-1/2" (64mmx64mm) 14 GA
UPRIGHTS	1-1/4" x 1-1/4" (32mm x 32mm) 16 GA or 14 GA

WELDS	Stainless Steel Mig Weld
FITTINGS	14 Gauge Stamp Forged Finish as below
FITTING FASTENERS	JS1000 Plated Finish as below
OPTIONAL FASTENER	Tamper Proof Nuts

FINISH

GRADE	Super Durable Polyester Powder Coat
OPTIONAL PRIMER	Zinc Rich Epoxy Powder Coat
OPTIONAL PRIMER (2)	E-Coat
STANDARD COLOUR	SEMI-GLOSS - BLACK
OTHER COLOURS	Green, Brown, White, Antique Silver
CUSTOM COLOURS	Per Specifications

STANDARD HEIGHTS	NA	NA	51" 1295mm	63" 1600mm	75" 1905mm
	Custom heights are available (upon request)				

STANDARD GATES	Passage, Double Entry, Cantilever
----------------	-----------------------------------

STANDARD POST SETTING & PANEL WIDTH

FOR FENCE HEIGHTS	PANEL WIDTH	POST SPACING [OPENING]
Up to 6' [1829mm]	92" [2337MM]	94" [2388 MM]
Over 6' [1829mm]	NA	